

XBLOC & XBLOCPLUS DESIGN GUIDELINES 2023

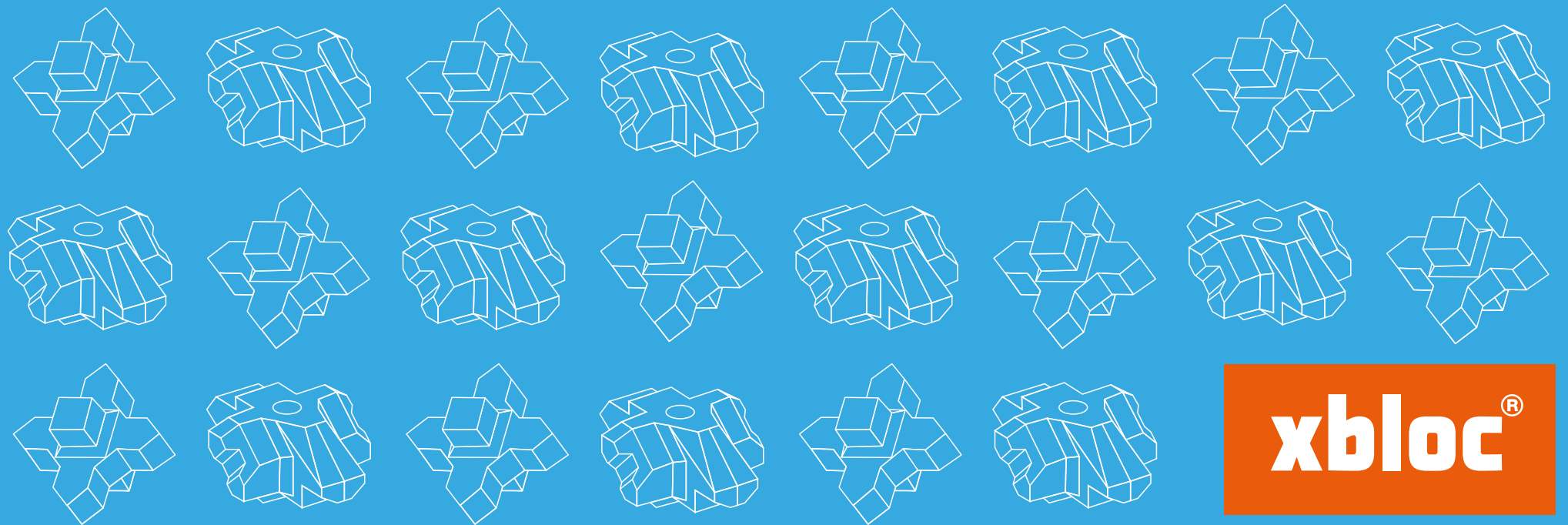
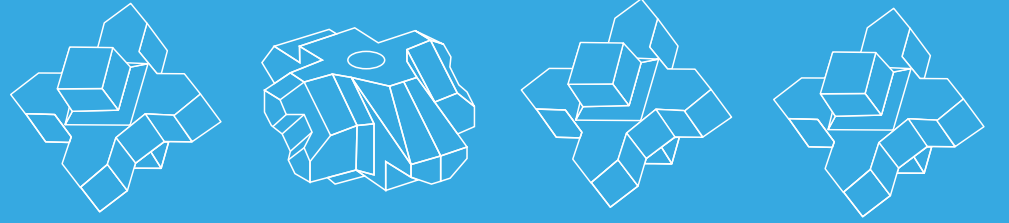

0.0 / INDEX

1.0	Introduction	4	6.3	Rocky seabed	20
2.0	The block shapes	7	6.4	Size of rock toe in front of Xbloc, Xbase or XblocPlus unit	20
3.0	Symbols and definitions	10	7.0	Crest design	22
4.0	Starting points and boundary conditions	12	8.0	Rear armour design	24
5.0	Front armour design	15	9.0	Overtopping	26
5.1	Required unit size	15	10.0	Breakwater head and curved sections	28
5.2	Underlayer	15	11.0	Transitions	32
5.3	Design table	15	11.1	Transitions Rock Armour to Xbloc	32
5.4	Local phenomena that affect the required unit size	19	11.2	Transitions between Xbloc sizes	32
5.5	Maximum allowable number of rows	19	11.3	Transitions Rock Armour to XblocPlus	33
6.0	Toe design	20	11.4	Transitions between XblocPlus sizes	33
6.1	Depth variation along alignment	20	11.5	Transitions with Xbloc and XblocPlus units	33
6.2	Sandy seabed	20	12.0	Conditions of use	34

1.0 / INTRODUCTION

Over the last decades, DMC has gained a vast experience in the design of breakwaters and shore protections. Since the development of the Xbloc, DMC has been involved in design, physical model testing and construction of many Xbloc projects around the world and over the last 5 years extensive knowledge has been obtained about the new XblocPlus.

The objective of this document is to share DMC's knowledge of Xbloc and XblocPlus and to help designers to easily design a cross section for their projects with Xbloc and XblocPlus.

Although the required unit size is determined mainly by the design wave conditions, a number of phenomena are presented which may require the application of a larger block. Furthermore, typical cross sections are presented along with various details.

This document is not a design manual and it is not a complete description of all factors that affect a design. The objective of this document is to provide general information to be used for concept designs with Xbloc and XblocPlus armour units. The design remains the responsibility of the designer who shall consider the various factors that affect the design. Physical model tests are always recommended by DMC to verify the stability of the design. The conditions which apply to the use of this document are described in Section 12.

In case of questions about a concept design or about the use of Xbloc or XblocPlus, please feel free to contact DMC at:

- xbloc@xbloc.com
- dmc@dmc.nl
- +31 182 590 610

Xbloc

Xbloc units are randomly placed armour blocks. Due to the angular shape of the Xblobs, the porosity of the Xbloc armour layer is high and the concrete consumption is low. Xbloc has been successfully applied on various projects around the world for more than 20 years.

In projects with Xbloc, Xbase can be applied as first row. The advantage of this block is that it rests flat on the bottom and doesn't roll away from its position. Xcrest can be used on the crest of a breakwater where it is very stable due to its low centre of gravity, the hole in the centre and its small exposure to waves. Xbase and Xcrest are made in the same mould as the Xbloc, but with a plate inserted into the mould to close off respectively one or two of the "noses" of the block. In Chapter 2 the block shapes are shown.

XblocPlus

XblocPlus units are regularly placed armour blocks. All units have the same orientation and are placed like roof tiles, each block on top of 2 other blocks in a staggered grid. The porosity of the armour layer is also high and the concrete

consumption of XblocPlus is equal to the concrete consumption of Xbloc. This is in fact approximately 10% lower than for other single layer blocks in the market.

XblocPlus units are larger than equivalent Xbloc units for the same wave conditions, but still the concrete consumption for both blocks is equal. As a consequence of the large size of the blocks, the blocks cover a large surface area on the breakwater slope. As a result, the number of XblocPlus units to place on a breakwater is 33% smaller than for other single layer blocks in the market.

On XblocPlus breakwaters, unit placement can be done quickly because of the ease of placement and the reduced number of blocks. To even further optimize your construction [time] XP-Wing, XP-Trans, XP-Overtop and XP-Crest can be used. These units can be produced by modifying the XblocPlus mould.

On straight or mildly curved sections the advantages of XblocPlus can be used to its full extent. For medium curves XblocPlus is combined with XP-Wing. On strongly curved sections or on roundheads, Xbloc units are used. Transitions between different sizes of XblocPlus units are realized with XP-Trans. With XP-Overtop the crest height and overtopping are reduced. XP-Crest is used to reduce the number of rows on the crest. With this unit only one row is required. Xcrest can also be used on the crest. In Chapter 2 the block shapes are shown.

Figure 1-1: Xbloc roundhead under construction

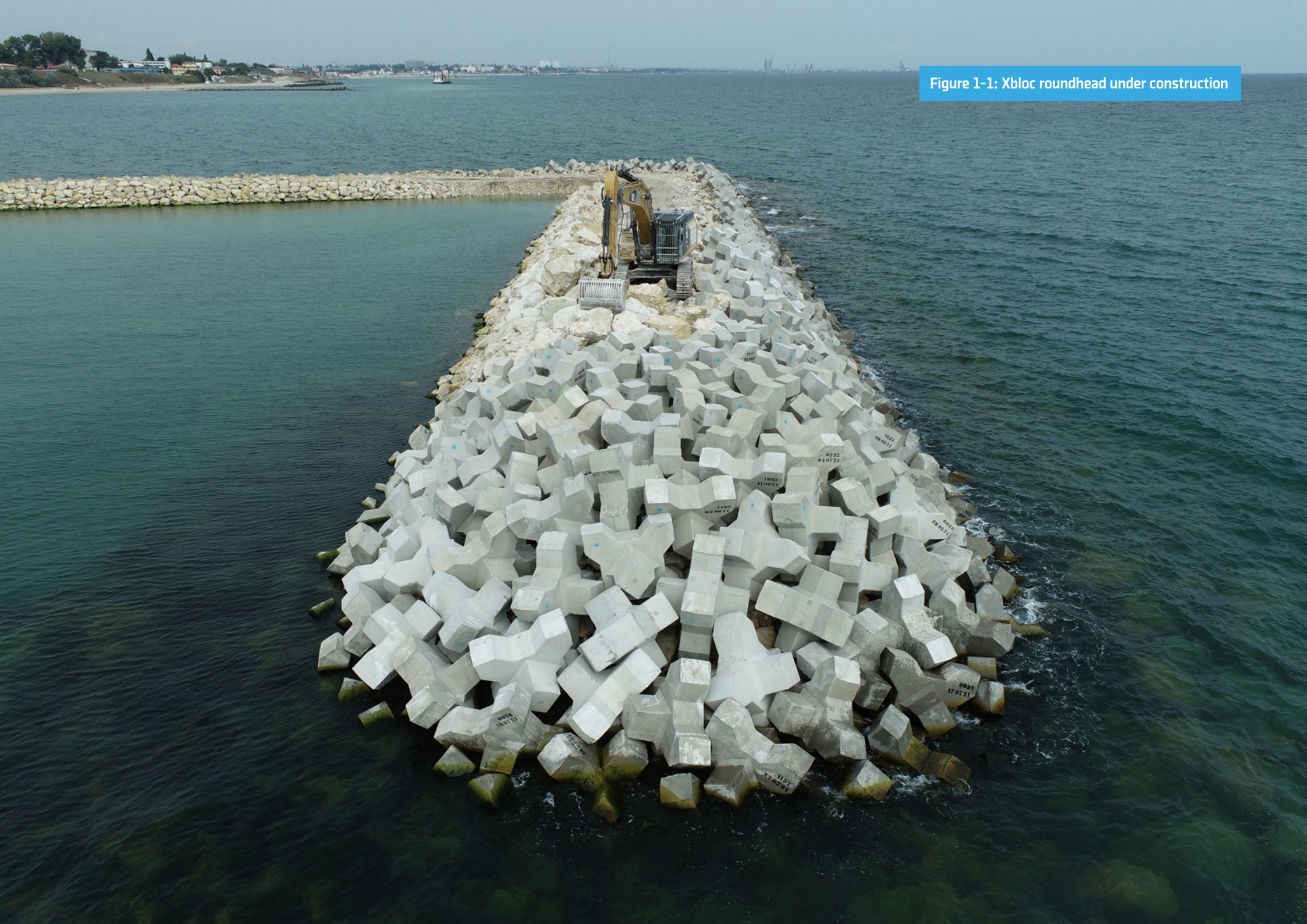

2.0 / THE BLOCK SHAPES

The following Xbloc units are available:

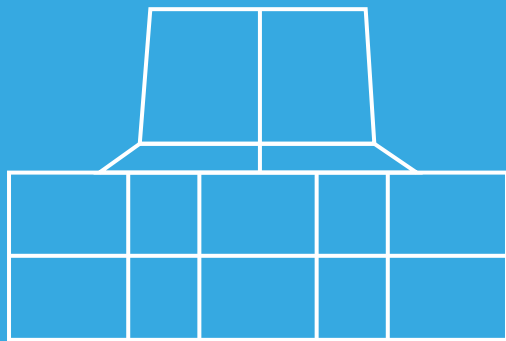

XBASE

Xbase units may be used as toe units in combination with Xbloc or as armour layer on the crest.

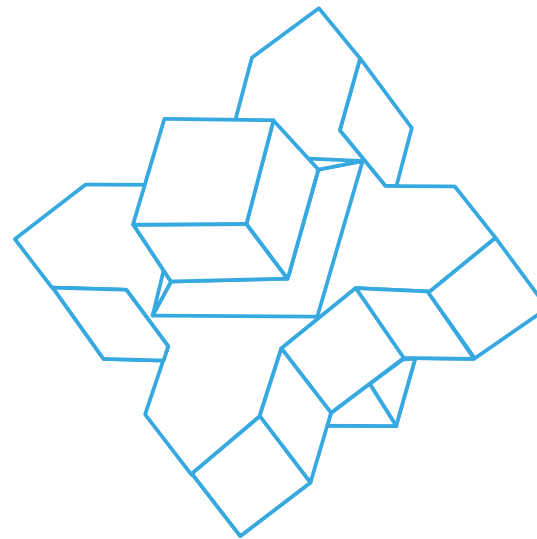

XBLOC

Xblocs can be used for a complete breakwater: straight sections, corners and breakwater heads

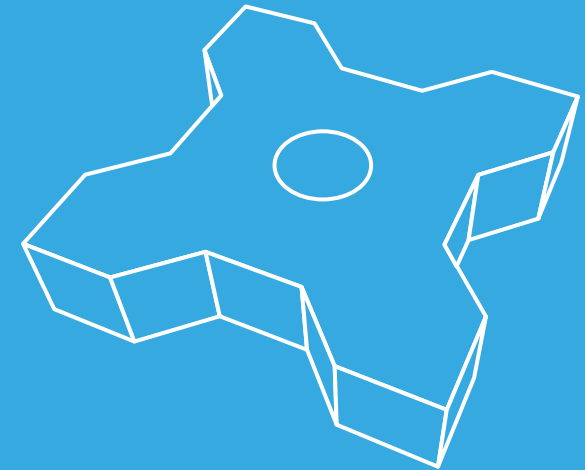

XCREST

Xcrest units may be used as armour layer on the crest.

The main dimensions of the Xbloc unit are:

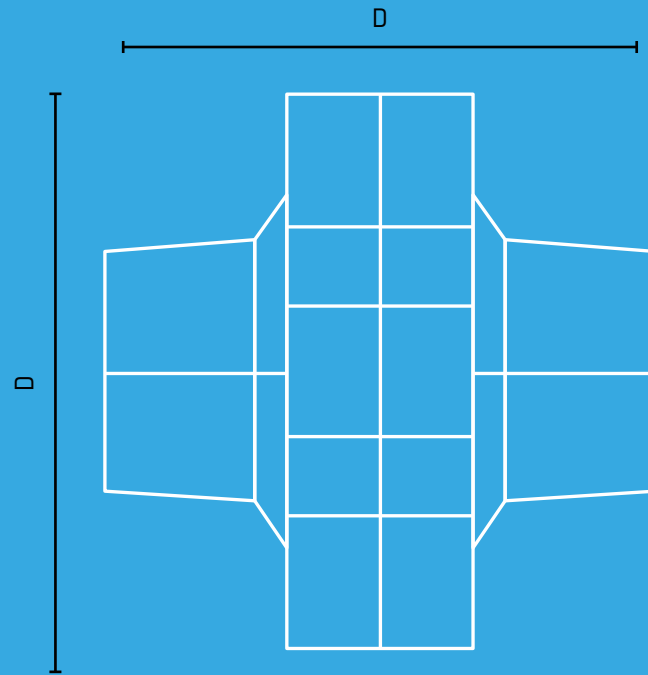

Side / top view

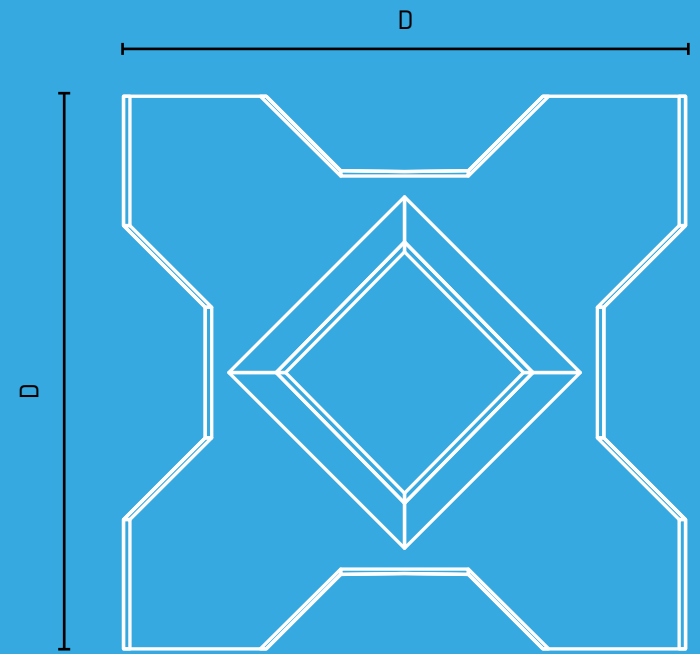

Front / Rear view

The following XblocPlus units are available:

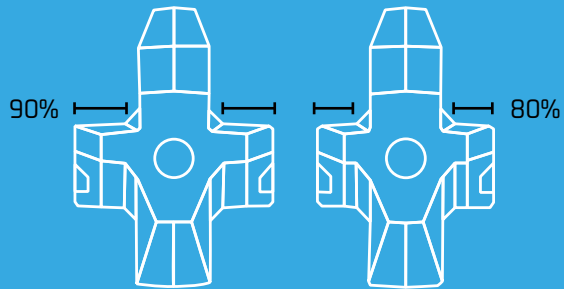

XP-WING

XP-Wing units are XblocPlus units with a reduced width [10% or 20% reduction] and may be used for medium curved sections in combination with XblocPlus.

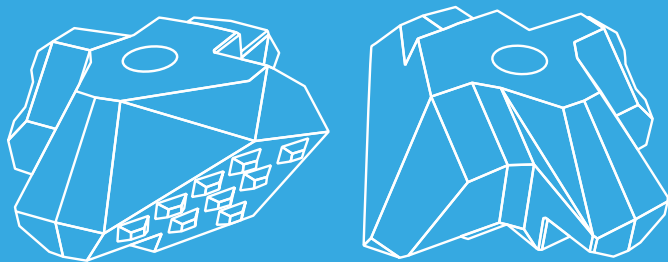

XP-TRANS

Transitions between different sizes of XblocPlus units are realized with XP-Trans where the smaller blocks lean on the bigger blocks.

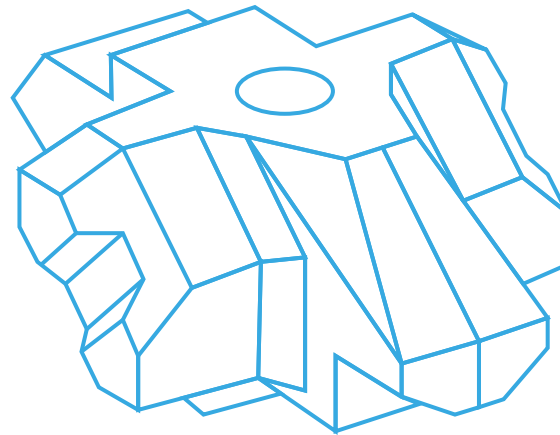

XBLOCPLUS

XblocPlus units are used for straight or mildly curved sections. For medium curved sections XP-Wing can be used. For strongly curved sections or on roundheads XblocPlus is combined with Xbloc.

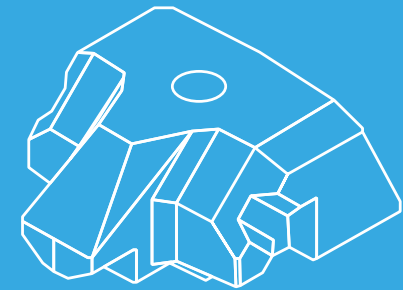

XP-CREST

For projects with a horizontal toe alignment, XP-Crest can be applied at the top of the armour slope. This block combines the function of an armour block with the function of a crown wall.

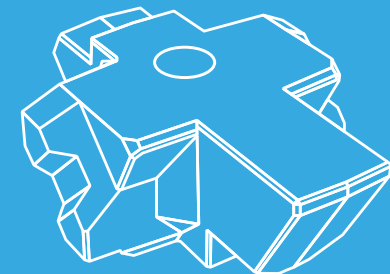

XP-OVERTOP

To reduce overtopping for an XblocPlus armour layer, XP-Overtop can be applied. Two rows of XblocPlus in the upper part of the slope are replaced by XP-Overtop units.

The main dimensions of the XblocPlus unit are:

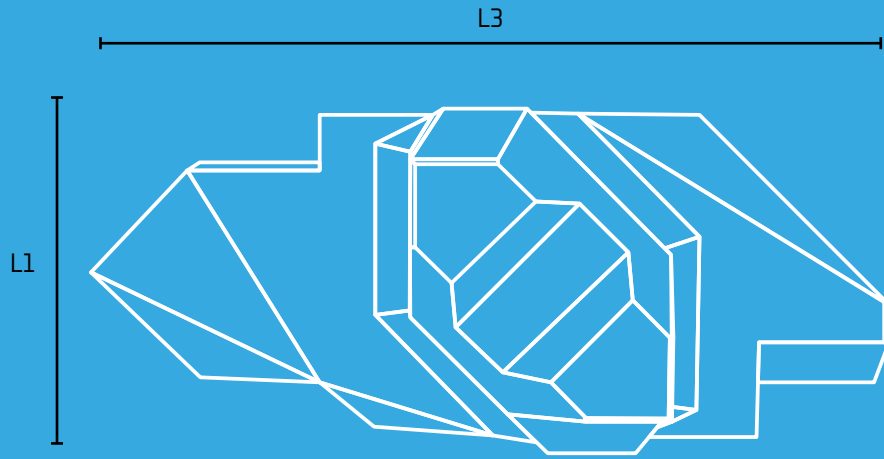

Side view

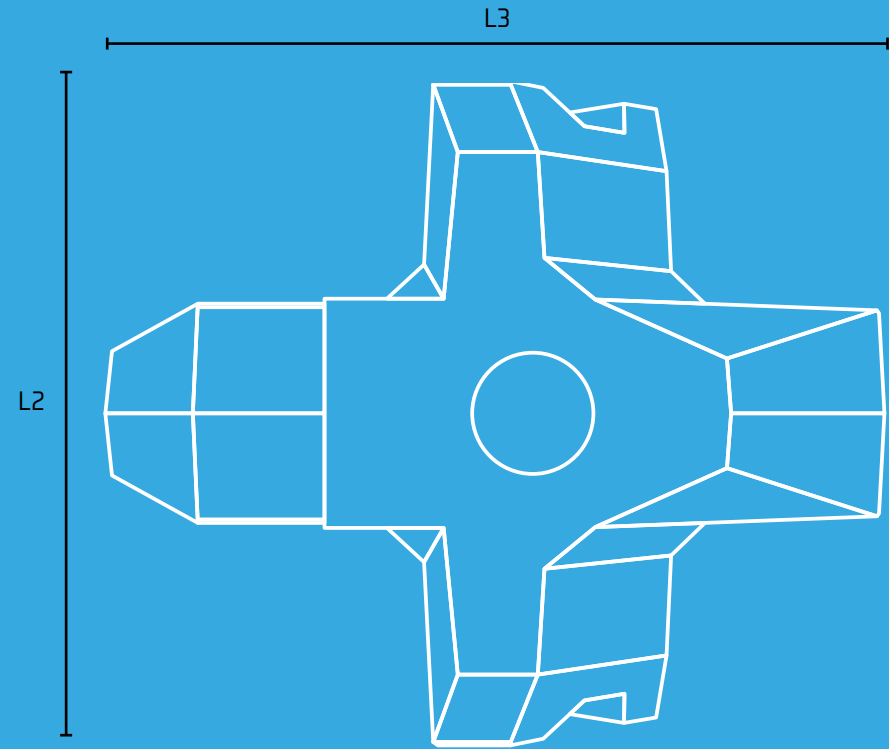

Top view

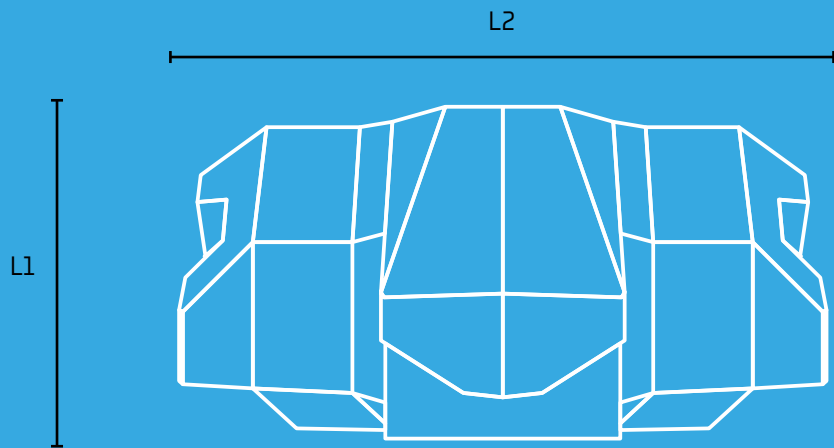

Front view

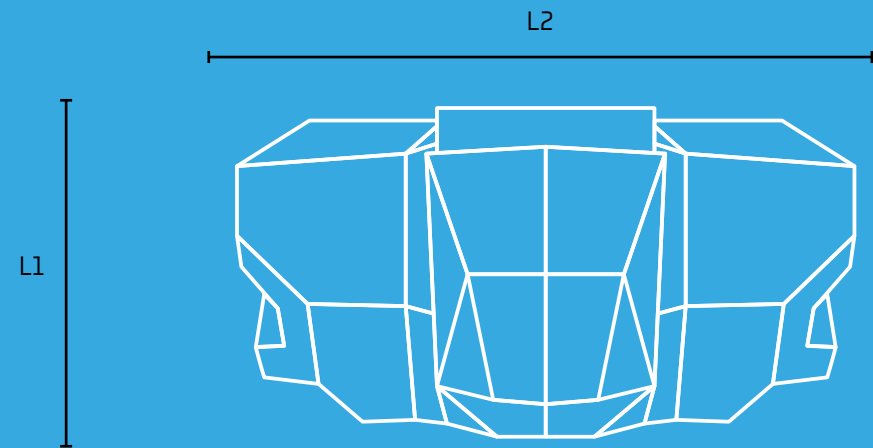

Rear view

3.0 / SYMBOLS AND DEFINITIONS

The following symbols are used in this document:

SYMBOL	DESCRIPTION	UNIT	SYMBOL	DESCRIPTION	UNIT
α	Slope angle	°	N	Packing density of Xbloc on slope	Units/m ²
Δ	Relative concrete density	-	n	Number of rows of units on the slope	-
D	Xbloc unit height	m	N _{od}	Damage value; number of displaced rocks	-
D _x	Horizontal c.t.c. distance between blocks along alignment	m	ρ_w	Mass density of seawater	kg/m ³
D _y	Upslope c.t.c. distance between blocks along alignment	m	ρ_c	Mass density of concrete	kg/m ³
D _{n50}	Median nominal diameter of rock	m	ρ_r	Mass density of rock	kg/m ³
FB	The freeboard: the crest height above the design high water level	m	Q	Mean overtopping discharge per meter structure width	m ³ /s/m
g	Acceleration due to gravity	m/s ²	R _c	Crest freeboard of the structure	m
H _{slope}	Vertical height of armour slope from centre lowest to centre highest block	m	RFB	Relative freeboard: the freeboard divided by the design wave height	-
h _{slope}	Vertical height of armour slope from bottom lowest to top highest block	m	R	Radius of breakwater head with Xbloc, measured at design high water level	m
H _s	Significant wave height based on time domain analysis	m	R _{min}	Minimum radius for XblocPlus, measured at lowest block	m
H _{m0}	Significant wave height calculated from wave spectrum	m	T _p	Peak wave period	s
h _t	Water depth above rock toe	m	V	Xbloc / XblocPlus unit volume	m ³
h	Water depth	m	W	Xbloc / XblocPlus unit mass	t
L1	XblocPlus unit height	m	γ_f	Roughness factor for overtopping calculation	-
L2	XblocPlus unit width	m			
L3	XblocPlus unit length	m			

Figure 3-1: Typical outline symbols and definitions

The following definitions are used in this document:

Armour layer	1	Outer layer of structure	Filter	7	Filter layer between sea bed and breakwater toe
Core	4	Inner part of breakwater	Underlayer	2	Rock layer between core and armour layer
Crest height	5	Top level of structure	Toe	3	Rock protection; foundation of armour layer
Crown wall	6	Concrete structure placed on breakwater crest			

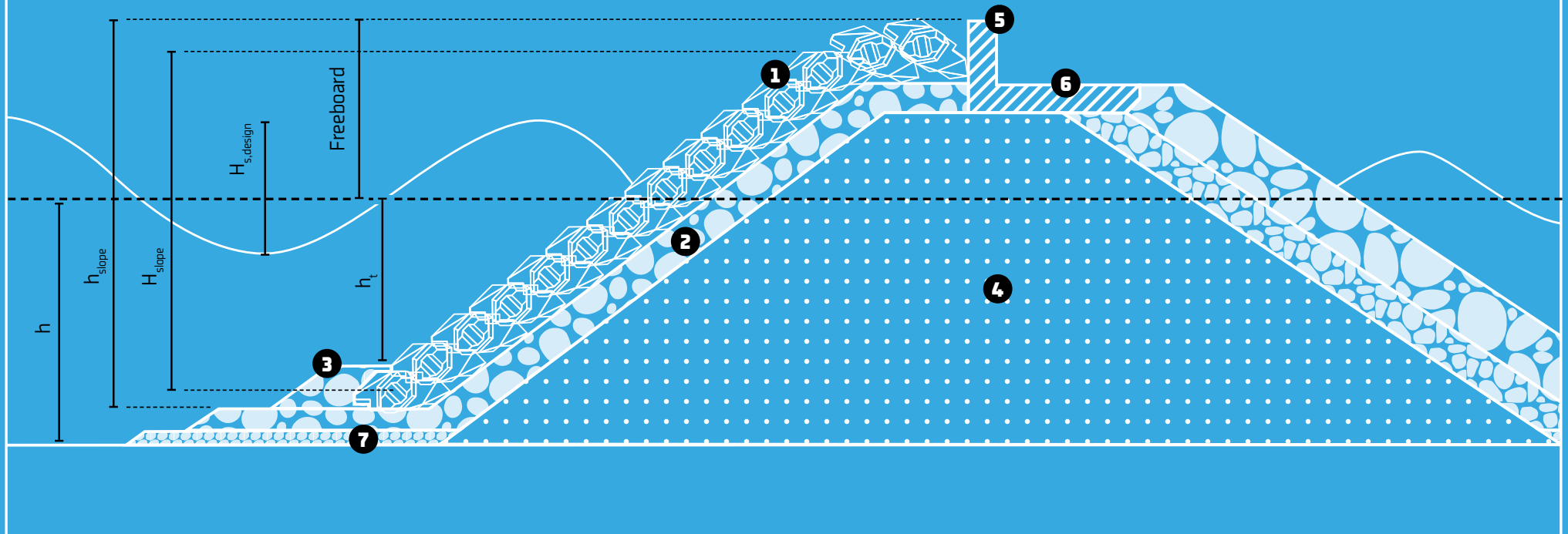

4.0 /

STARTING POINTS AND BOUNDARY CONDITIONS

12

The most important starting points for the design of a breakwater / shore protection are:

- The required lifetime of the structure;
- The return period of the design conditions;
- Allowable overtopping;
- Allowable wave disturbance behind a breakwater;
- Construction aspects [e.g. crest width and height].

The most important boundary conditions for the design of a breakwater / shore protection are:

- The design wave height and period;
- The design water level [high water and low water];
- The bathymetry;
- The soil conditions;
- Seismic conditions.

The geotechnical design of breakwaters and shore protections is determined by local soil conditions, surcharge loads, hydraulic loads and seismic conditions. These aspects should be carefully considered by the design consultant and are not a part of this document.

Figure 4-1: XblocPlus placement



Figure 5-1: XblocPlus slope under construction



5.0 /

FRONT ARMOUR DESIGN

The required armour size is typically determined by the design wave height as described in Section 5.1. Depending on the local conditions, there are however phenomena that may require the application of a larger unit than based on the equation as described in Section 5.1. These phenomena are described in Section 5.4.

5.1 REQUIRED UNIT SIZE

For the design of typical cross sections of breakwaters and shore protection, the required Xbloc or XblocPlus size depends on the design wave height and can be determined with the following formula:

Xbloc

$$V_{\text{Xbloc}} = \left[\frac{H_s}{2.77 \times \Delta} \right]^3$$

XblocPlus

$$V_{\text{XblocPlus}} = \left[\frac{H_s}{2.5 \times \Delta} \right]^3$$

Where

V	Unit volume	[m ³]
H _s	Design significant wave height ¹⁾²⁾	[m]
Δ	Relative concrete density $[\rho_c - \rho_w] / \rho_w$	[-]
ρ _w	Mass density of seawater	[kg/m ³]
ρ _c	Mass density of concrete ³⁾	[kg/m ³]

- DMC does not recommend a reduction for oblique waves without physical model tests.
- If H_{mo} is higher than H_s, H_{mo} shall be applied.
- DMC does not recommend the use of concrete densities outside the range of 2350-2500kg/m³.

This formula in fact gives the same results as the Hudson formula for an armour slope steepness of 3V:4H and a Kd factor of 16 for Xbloc and a Kd factor of 12 for XblocPlus. It is important to note that for Xbloc and XblocPlus on a milder slope, the required unit weight is not reduced.

Xblocs are typically applied on an armour slope steepness between 3V:4H and 2V:3H. But milder slopes are possible.

5.2 UNDERLAYER

The mass of the underlayer M₅₀ shall be between a certain bandwidth of the unit mass. Depending on project conditions [e.g. wave climate during construction, or quarry production] it can be chosen to apply a finer or coarser underlayer within the range presented in the table below. In the design table [Table 5-1 and Table 5-2] these ranges are given for each unit size.

	Xbloc	XblocPlus
M ₅₀ of underlayer between	1/6 th to 1/15 th of unit mass	1/8 th to 1/20 th of unit mass

5.3 DESIGN TABLE

An overview of the different Xbloc and XblocPlus unit sizes, their design wave height and properties along with suitable underlayers are given in Table 5-1 for Xbloc and Table 5-2 for XblocPlus. These tables are based on ρ_{concrete} = 2400 kg/m³ and ρ_{water} = 1030 kg/m³.

Table 5-1: Dimensions of various parts of shore protection structure using Xbloc based on design wave height

Unit volume V [m³]	Design wave height H _s [m]	Unit height D [m]	Unit weight W [t]	Thickness of armour layer h [m]	Packing density N [1/100m²]	Concrete volume [m³/m²]	Placement distance horizontal D _x [m]	Placement distance up-slope D _y [m]	Porosity of armour layer [%]	Minimum M ₅₀ rock underlayer [t]	Maximum M ₅₀ rock underlayer [t]
0.75	3.35	1.31	1.8	1.3	70.0	0.53	1.73	0.83	58.7	0.12	0.30
1	3.69	1.44	2.4	1.4	57.8	0.58	1.90	0.91	58.7	0.16	0.40
1.5	4.22	1.65	3.6	1.6	44.1	0.66	2.18	1.04	58.7	0.24	0.60
2	4.65	1.82	4.8	1.8	36.4	0.73	2.40	1.14	58.7	0.32	0.80
2.5	5.01	1.96	6.0	1.9	31.4	0.78	2.58	1.23	58.7	0.40	1.00
3	5.32	2.08	7.2	2.0	27.8	0.83	2.75	1.31	58.7	0.48	1.20
4	5.86	2.29	9.6	2.2	22.9	0.92	3.02	1.44	58.7	0.64	1.60
5	6.31	2.47	12.0	2.4	19.8	0.99	3.26	1.55	58.7	0.80	2.00
6	6.70	2.62	14.4	2.5	17.5	1.05	3.46	1.65	58.7	0.96	2.40
7	7.06	2.76	16.8	2.7	15.8	1.11	3.64	1.74	58.7	1.12	2.80
8	7.38	2.88	19.2	2.8	14.5	1.16	3.81	1.82	58.7	1.28	3.20
9	7.67	3.00	21.6	2.9	13.4	1.20	3.96	1.89	58.7	1.44	3.60
10	7.95	3.11	24.0	3.0	12.5	1.25	4.10	1.96	58.7	1.60	4.00
12	8.44	3.30	28.8	3.2	11.0	1.32	4.36	2.08	58.7	1.92	4.80
14	8.89	3.48	33.6	3.4	10.0	1.39	4.59	2.19	58.7	2.24	5.60
16	9.29	3.63	38.4	3.5	9.1	1.46	4.80	2.29	58.7	2.56	6.40
18	9.67	3.78	43.2	3.7	8.4	1.52	4.99	2.38	58.7	2.88	7.20
20	10.01	3.91	48.0	3.8	7.9	1.57	5.17	2.47	58.7	3.20	8.00

Table 5-2: Dimensions of various parts of shore protection structure using XblocPlus based on design wave height

Unit volume V [m ³]	Design wave height H _s [m]	Unit height L1 [m]	Unit width L2 [m]	Unit length L3 [m]	Unit weight W [t]	Thickness of Armour layer h [m]	Packing density N [1/100m ²]	Concrete volume [m ³ /m ²]	Placement Distance horizontal D _x [m]	Placement distance up-slope D _y [m]	Porosity of armour layer [%]	Minimum M ₅₀ rock underlayer [t]	Maximum M ₅₀ rock underlayer [t]
0.75	3.02	0.75	1.51	1.91	1.8	1.2	63.7	0.48	1.66	0.95	60.3	0.09	0.23
1	3.33	0.83	1.66	2.10	2.4	1.3	52.6	0.53	1.82	1.04	60.3	0.12	0.30
1.5	3.81	0.95	1.90	2.41	3.6	1.5	40.1	0.60	2.09	1.19	60.3	0.18	0.45
2	4.19	1.04	2.09	2.65	4.8	1.7	33.1	0.66	2.30	1.32	60.3	0.24	0.60
2.5	4.51	1.12	2.25	2.85	6.0	1.8	28.5	0.71	2.47	1.42	60.3	0.30	0.75
3	4.80	1.19	2.39	3.03	7.2	1.9	25.3	0.76	2.63	1.51	60.3	0.36	0.90
4	5.28	1.31	2.63	3.34	9.6	2.1	20.9	0.83	2.89	1.66	60.3	0.48	1.20
5	5.69	1.42	2.83	3.59	12.0	2.3	18.0	0.90	3.12	1.78	60.3	0.60	1.50
6	6.04	1.50	3.01	3.82	14.4	2.4	15.9	0.96	3.31	1.90	60.3	0.72	1.80
7	6.36	1.58	3.17	4.02	16.8	2.5	14.4	1.01	3.49	2.00	60.3	0.84	2.10
8	6.65	1.66	3.31	4.20	19.2	2.7	13.2	1.05	3.64	2.09	60.3	0.96	2.40
9	6.92	1.72	3.45	4.37	21.6	2.8	12.2	1.09	3.79	2.17	60.3	1.08	2.70
10	7.16	1.78	3.57	4.53	24.0	2.9	11.3	1.13	3.93	2.25	60.3	1.20	3.00
12	7.61	1.89	3.79	4.81	28.8	3.0	10.0	1.20	4.17	2.39	60.3	1.44	3.60
14	8.01	1.99	3.99	5.06	33.6	3.2	9.1	1.27	4.39	2.51	60.3	1.68	4.20
16	8.38	2.09	4.17	5.29	38.4	3.3	8.3	1.33	4.59	2.63	60.3	1.92	4.80
18	8.71	2.17	4.34	5.50	43.2	3.5	7.7	1.38	4.77	2.73	60.3	2.16	5.40
20	9.03	2.25	4.50	5.70	48.0	3.6	7.1	1.43	4.95	2.83	60.3	2.40	6.00

Table 5-3: Correction factors for local phenomena that affect the required unit size

Phenomenon	Effect on Armour Stability	Correction factor on unit weight	
		Xbloc	XblocPlus
Frequent occurrence of near-design wave height during the lifetime of the structure	Rocking of units, which can occur for a small percentage of the armour units during the design event of a breakwater, can occur frequently during the lifetime of the structure. Therefore, rocking should be carefully assessed during the physical model tests.	1.25	Not applicable [as rocking was not observed during XblocPlus model tests]
The foreshore in front of the structure is steep	A steep foreshore can lead to adverse wave impact against the armour layer.	1.1 for a steepness between 1:30 and 1:20 1.25 for a steepness between 1:20 and 1:15 1.5 for a steepness between 1:15 and 1:10 2 for a steepness greater than 1:10	
The structure is low crested	Armour units placed on the horizontal crest and high on the slope are less stable than units placed lower on the slope, where interlocking is increased by gravity and the above-lying units. In case of a low breakwater the crest area sustains wave impacts and as a consequence a larger unit size is applied.	2 for a relative freeboard < 0.5 1.5 for a relative freeboard < 1	1.5 for a relative freeboard < 0.5 1.25 for a relative freeboard < 1
The water depth is large	For typical nearshore breakwater cross sections, the ratio between the highest wave heights in the spectrum and the significant wave height is in the order of 1.2 – 1.4. For breakwaters in deep water, this ratio can be up to 1.8 – 2. As the largest waves in the spectrum cause the largest loads on the armour layer, the stability of the armour layer is reduced compared to breakwaters in lower water depths. Furthermore, a breakwater cross section in deep water typically contains a high rock toe which can affect the wave impacts on the armour slope. Therefore, rocking should be carefully assessed during the physical model tests.	1.5 for water depth > 2.5 x Hs 2 for water depth > 3.5 x Hs	Not applicable [as stability was demonstrated in model tests with deep water conditions for stability numbers > 2.5]
The core permeability is low	A low core permeability can lead to large pressures in the armour layer and reduce the stability of the armour layer. The permeability of the core depends on the materials used and the distance at the water line between the armour layer and the impermeable layer.	1.5 for low core permeability 2 for an impermeable core	1.25 for low core permeability 1.5 for an impermeable core
The armour slope is mild [$<1:1.5$]	On a mild slope, the interlocking of the armour units is less effective and as a consequence the stability is reduced.	1.25 [slope milder than 2:3] 1.5 [slope milder than 1:2]	Not applicable [as model tests showed no decrease in stability for milder slopes]

5.4 LOCAL PHENOMENA THAT AFFECT THE REQUIRED UNIT SIZE

The design formula and design tables presented in the previous section are applicable for typical cross sections of breakwaters and shore protections. There are however a number of phenomena which require an increase in the Xbloc or XblocPlus unit sizes. The phenomena and the proposed correction factors for the required Xbloc or XblocPlus unit size are described in table 5-3.

For the concept design of structures where one or more of these phenomena apply, the following design formula are recommended:

$$V_{\text{Xbloc}} = \left[\frac{H_s}{2.77 \times \Delta} \right]^3 \times \text{Correction Factor}$$

$$V_{\text{XblocPlus}} = \left[\frac{H_s}{2.5 \times \Delta} \right]^3 \times \text{Correction Factor}$$

If more than one of the above-mentioned phenomena is applicable to a design, it is advised to apply the largest correction factor as a starting point for the physical model tests.

These correction factors are presented with the objective to make designers aware of the effect of these phenomena and to give a first estimate of the required Xbloc and XblocPlus size in a project. It should be noted that the factors presented should be used with care as these are based more on project specific model test experience rather than on vast research programs. For the detailed design, physical model tests are always recommended.

Although this document focuses on the design of Xbloc and XblocPlus breakwaters and shore protection, DMC expects that the phenomena described above also apply to other armour units which derive their stability from interlocking.

5.5 MAXIMUM ALLOWABLE NUMBER OF ROWS

Another phenomenon which may require applying a larger armour unit than purely based on the design formula presented in section 5.1 is a high breakwater slope [large slope length].

Xbloc

To limit possible settlements the maximum number of rows on the slope is 20 for Xblocs. This results in a maximum slope length of $19 \times Dy + 0.5 \times D$ where Dy is the upslope distance between the Xblocs and D is the characteristic height of the Xbloc.

If the slope length requires more than 20 rows, there are 2 possible solutions:

- Increase the unit size and/or;
- Raise the toe level by applying a rock berm.

It should be noted that applying a berm may affect the wave impacts on the armour slope. Therefore, this solution may still lead to applying a larger armour unit.

XblocPlus

Since XblocPlus is less sensitive to settlements within the armour layer than other single layer armour units, the limitation on the number of rows is less critical. Therefore, there is no limit of 20 rows like most other single layer blocks and Xblocs. Nonetheless a high number of rows on the slope leads to a disproportionately thin armour layer in relation to the water depth. For a design with more than 25 rows please consult with DMC.

For the design of the toe, the combination of wave heights and water levels shall be carefully considered. In a depth limited situation, the toe design shall be checked for various water levels with corresponding wave height combinations. If the design wave conditions can occur during design low water level, this combination will be governing.

6.1 DEPTH VARIATION ALONG ALIGNMENT

If the water depth varies along the breakwater alignment, the number of units on the slope will vary along the alignment. DMC generally recommends designing the breakwater toe in such a way that it follows the seabed [hence not having sudden changes in the seabed level along the alignment]. The maximum gradient for which this is recommended is 1V:10H. For steeper gradients, the toe should be levelled either by filling with rock material or by dredging. For XblocPlus breakwaters it is important that changes in toe alignment shall be gradual.

6.2 SANDY SEABED

For a sandy seabed DMC recommends the following toe geometry:

- A rock filter layer or a geotextile with a protective small rock layer on top;
- Foundation layer underneath the first layer of XblocPlus, Xbloc or Xbase units. Typically, the rock size applied in this layer has a W50 of the unit divided by 30;
- A rock toe in front of the units.

The minimum dimensions of the rock toe are indicated in Figure 6-1. In section 6.4 the required mass of the rock is described.

In very shallow water depths, it may be impossible to design a toe as the required rock size becomes too large. In such situations, it can be considered to dig a trench below the toe of the slope and fill this trench with rock layers. This geometry is also suitable in situations with a risk of scour.

6.3 ROCKY SEABED

For a rocky seabed, the toe geometry is slightly different as there is no need for filter layers. In this case, the toe consists of:

- A row of Xbloc, Xbase or XblocPlus units placed on the seabed;
- A rock toe in front of the first row of Xbloc, Xbase or XblocPlus units.

Then minimum dimensions of the toe on a rocky seabed are indicated in Figure 6-3. In section 6.4 the required mass of the rock is described.

In this situation the smoothness and gradient of the seabed should be considered. If the gradient of the seabed is larger than 1V:10H, the seabed should be smoothed by dredging or by an additional rock layer between the seabed and the first unit.

6.4 SIZE OF ROCK TOE IN FRONT OF XBLOC, XBASE OR XBLOCPLUS UNIT

The required rock size depends on the water depth and the wave height. A prediction of the required rock mass can be derived by the generic approach developed by Van der Meer et al. [1995]. The formula derived by Van der Meer is given below:

$$D_{n50} = \frac{H_s}{\left[2 + 6.2 \left(\frac{h_t}{h} \right)^{2.7} \right] \times N_{od}^{0.15} \Delta}$$

Where

D_{n50}	Median nominal diameter of rock	[m]
H_s	Design significant wave height	[m]
h_t	Depth above toe	[m]
h	Water depth in front of toe	[m]
N_{od}	Damage value Number of displaced units	[-]
Δ	Relative concrete density $[\rho_c - \rho_w] / \rho_w$	[-]
ρ_w	Mass density of seawater	[kg/m ³]
ρ_r	Mass density of rock	[kg/m ³]

It is recommended to design the required toe size with a N_{od} value of 0.5 [start of damage], but a value of 2 may be applied if the rock toe is sufficiently wide to allow for some flattening out [responsibility of the designer].

**Figure 6-1: Typical toe layout on sandy seabed
[if required, a geotextile shall be applied
between seabed and core layer]**

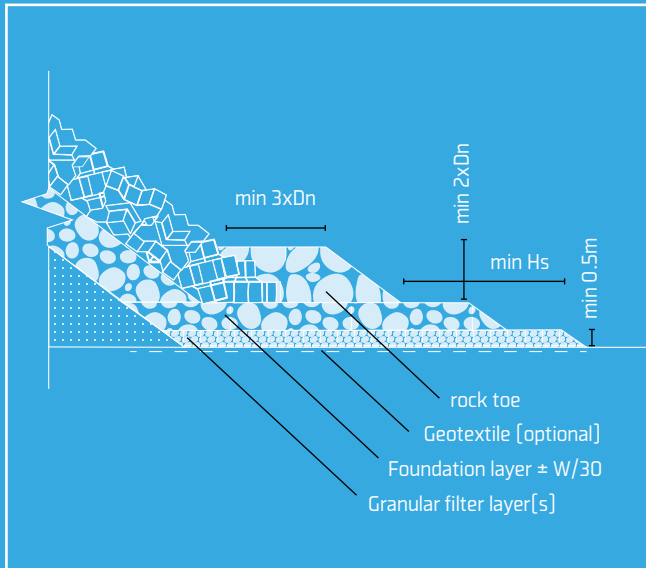

**Figure 6-2: Toe layout on sandy seabed in
very shallow water depths**

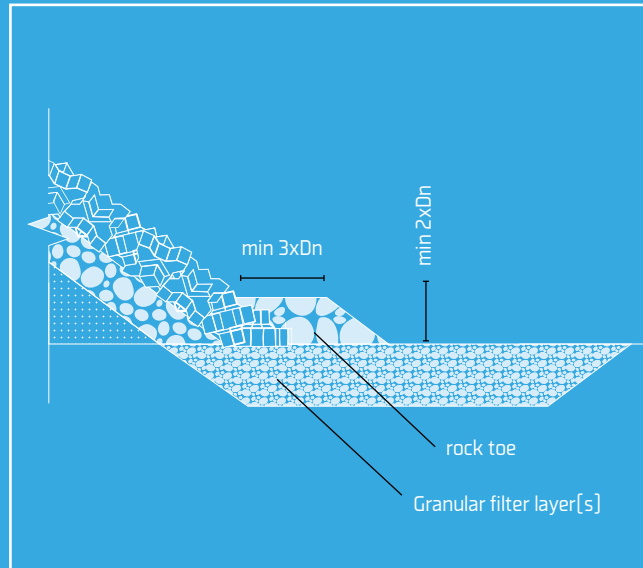
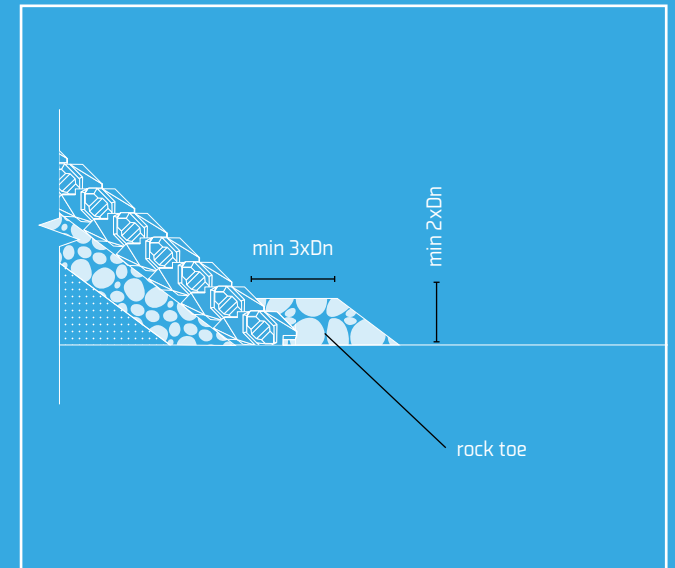
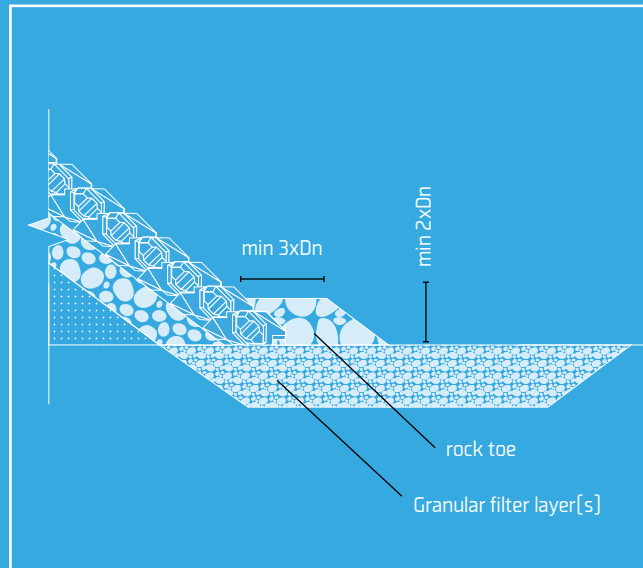
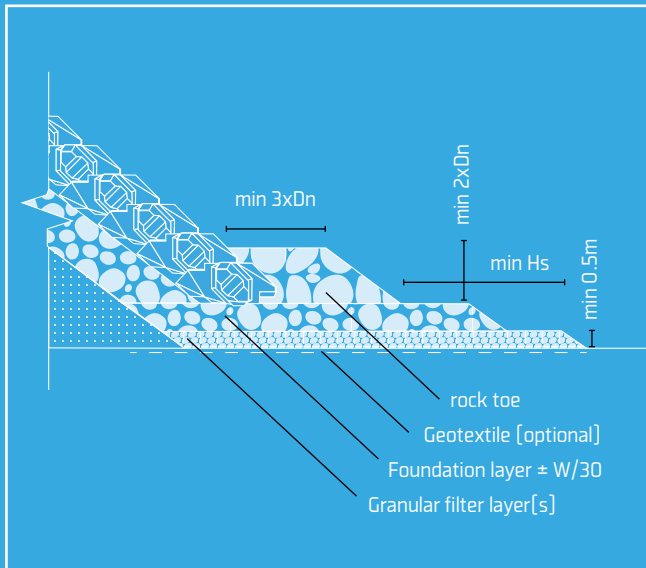
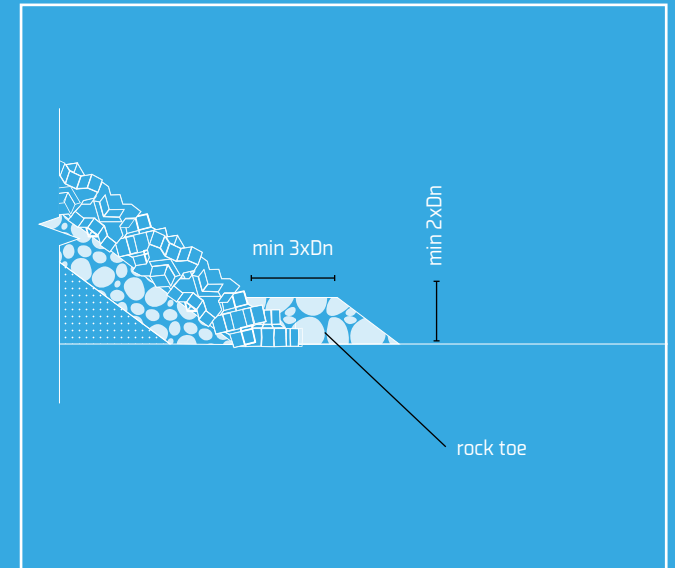

Figure 6-3: Typical toe layout on rocky seabed



The design of the breakwater or shore protection crest depends on:

- Required crest level;
- Whether road access is required on the breakwater / shore protection and by whom it will be used (access road or service road only);
- The allowable overtopping;
- The crest width at a certain level required for construction purposes.

Figures 7-1 and 7-2 give an overview of typical crest designs with Xbloc. These depend on the relative freeboard and whether or not access to the breakwater is required (with a crown element or not). The crown elements given in Figure 7-2 are indicative only. The hydraulic stability of the crown elements can be critical and shall be assessed in a concept design.

It should be noted that these are typical sketches and that physical model tests are recommended for the crest design, especially if the freeboard is low.

If the breakwater has a relative freeboard of 0.8 – 1.2, it is recommended to place at least 2 armour units in front of the crown wall. This corresponds to a width of $1.64D$ where D is the characteristic unit height. Without a crown wall it is recommended to apply at least 3 armour units on the crest, which corresponds to a minimum crest width of $2.28D$.

In case the crest height of the breakwater has a relative freeboard of 1.2 – 1.5 the recommended minimum crest width in front of a crown wall is $1D$, which corresponds to placing 1 unit on the crest.

The stability of the XblocPlus units on a crest is higher than for Xbloc units due to the fact that the wave loads on the new block are lower (block shape and hole to release wave pressures). Also XP-Crest units or Xcrest can be used on the crest.

It should be noted that it is recommended to confirm these designs with model tests.

Figure 7-1: Typical crest and rear armour design without crest structure [depending on relative freeboard]

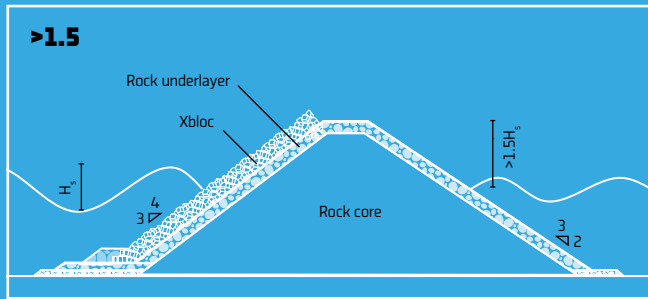
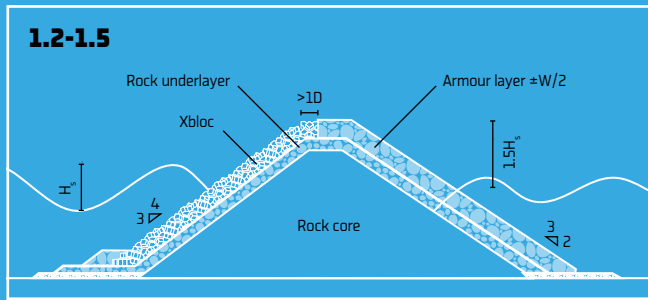
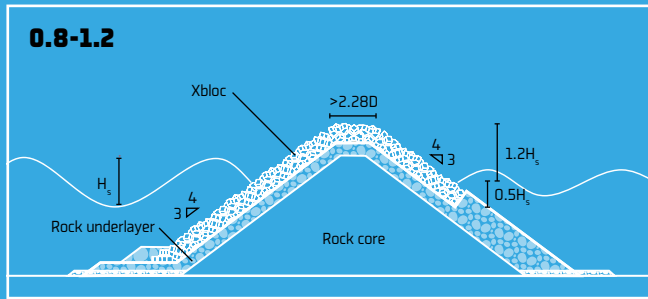
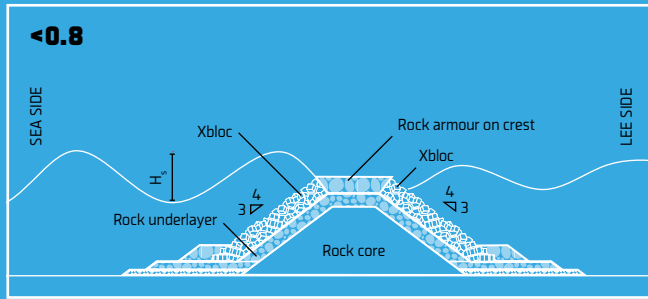

Figure 7-2: Typical crest and rear armour design with crest structure [depending on relative freeboard]

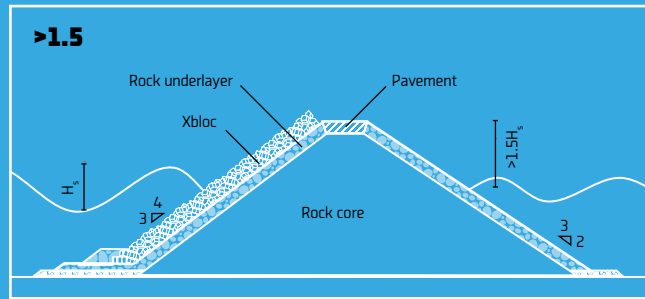
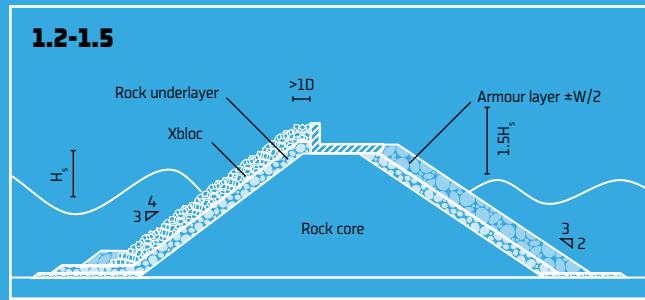
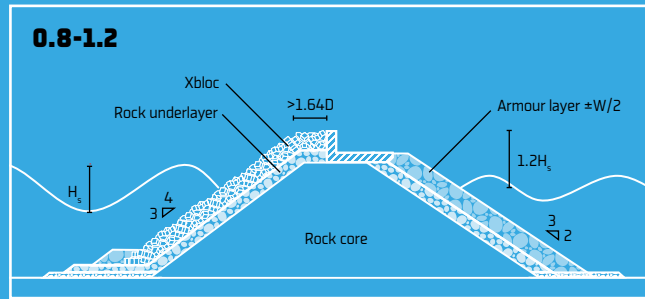
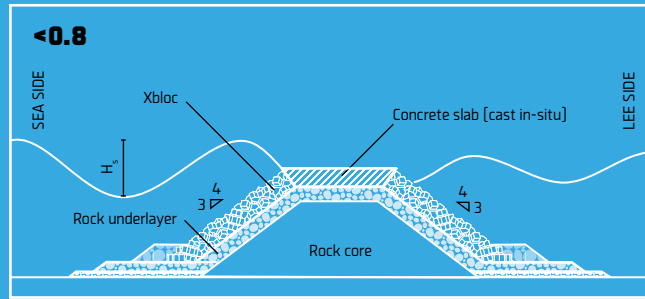
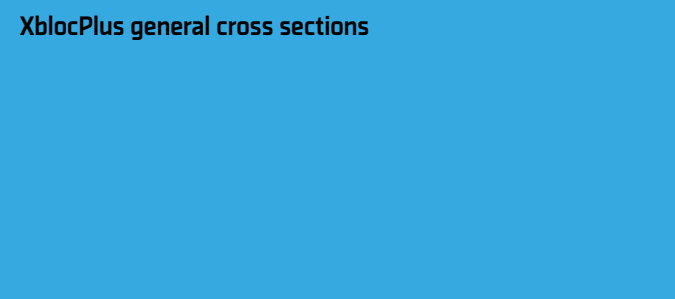
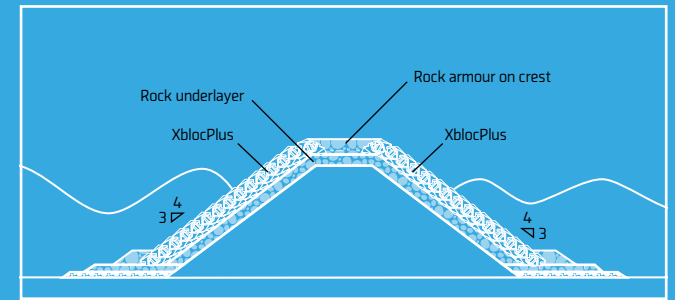
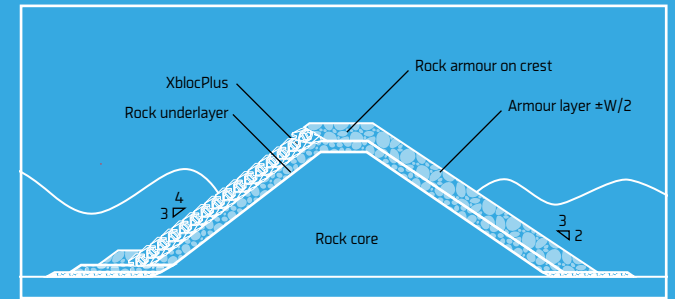
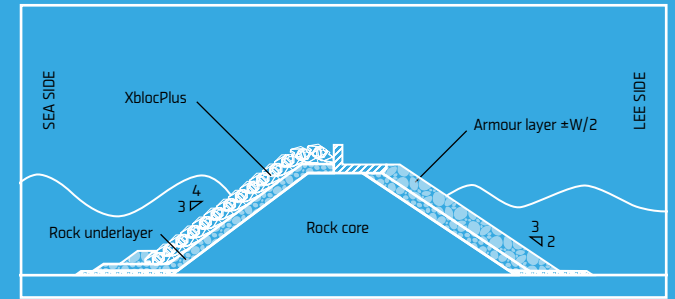

Figure 7-3: Typical crest and rear armour design with XblocPlus



XblocPlus general cross sections

Xbloc, without crown wall:

Xbloc, with crown element:

8.0 /

REAR ARMOUR DESIGN

24

The design of the rear armour is determined by:

- The overtopping waves;
- The waves at the rear side of the breakwater [mostly as a result of wave penetration].

There is no generic design formula for the rear armour as the geometry of the breakwater has a large impact on overtopping volumes and wave loads at the rear armour. Figure 7-1 to 7-3 give an overview of the rear armour at typical breakwater cross sections depending on the relative freeboard and whether or not access to the breakwater is required.

Please note that these are typical sketches and that physical model tests are required for detailed rear armour design.

Figure 8-1: XblocPlus production and storage yard



9.0 / OVERTOPPING

For Xbloc and XblocPlus, the equations from the EurOtop manual [2016] can be used to calculate the expected overtopping volumes.

The roughness coefficient of Xbloc is $\gamma_f = 0.44$.

The roughness coefficient of the XblocPlus has been determined in hydraulic model tests. The roughness coefficient has a value of $\gamma_f = 0.45$, see Figure 9-1. This value is based on overtopping tests done by DMC and by the University of Ghent.

To further reduce overtopping for an XblocPlus armour layer, XP-Overtop can be applied. Two rows of XblocPlus in the upper part of the slope are replaced by XP-Overtop units, see Figure 9-3. The roughness coefficient of the armour layer is reduced to 0.41-0.42 depending on the relative freeboard. With Figure 9-2 the reduction in crest height can be determined when applying XP-Overtop instead of an armour with solely XblocPlus for the same overtopping.

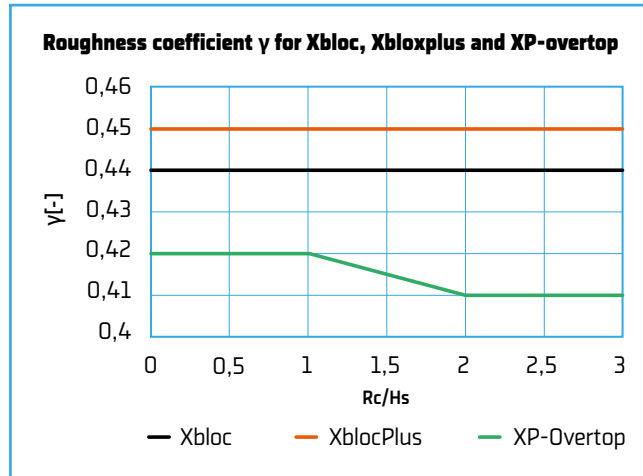

Figure 9-1: Roughness coefficient for Xbloc, XblocPlus and XP-Overtop

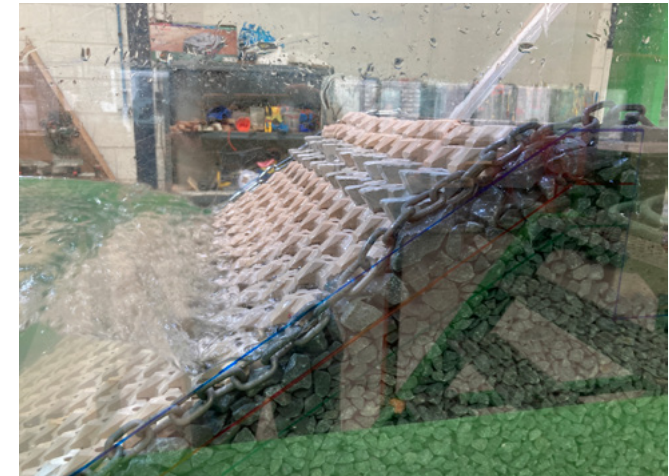

Figure 9-3: Model slope with XP-Overtop in the upper part

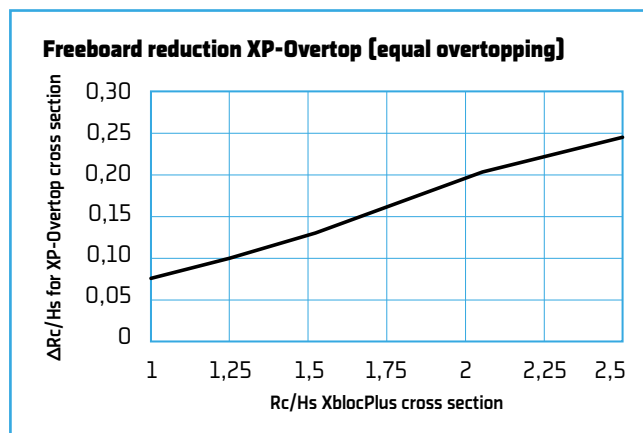

Figure 9-2: Freeboard reduction for XP-Overtop

Figure 9-4: Xbloc under severe wave attack



XblocPlus units are used on straight or mildly curved breakwater sections where the advantages of the unit can be used to its full extent: fast placement due to its roof tile principle. For medium curved sections XblocPlus units are combined with XP-Wing. On strongly curved sections or on roundheads, Xbloc units are applied as these allow for flexible placement on curved surfaces.

This section describes which radius can be achieved with XblocPlus and the application of XP-Wing. It also describes which Xbloc size is required on a strongly curved section or breakwater head and the minimum radius that can be achieved with Xblocs.

Minimum Radius for Sections with XblocPlus

The relationship between the minimum radius of a breakwater, the block size and the height of the armour layer is presented for a 3:4 slope steepness and a 1:1.5 slope steepness in Figure 10-1. The parameters are shown schematically in Figure 10-2.

Figure 10-1: Relationship between the minimum radius at the breakwater toe and the block size, number of rows and height of the breakwater slope for XblocPlus

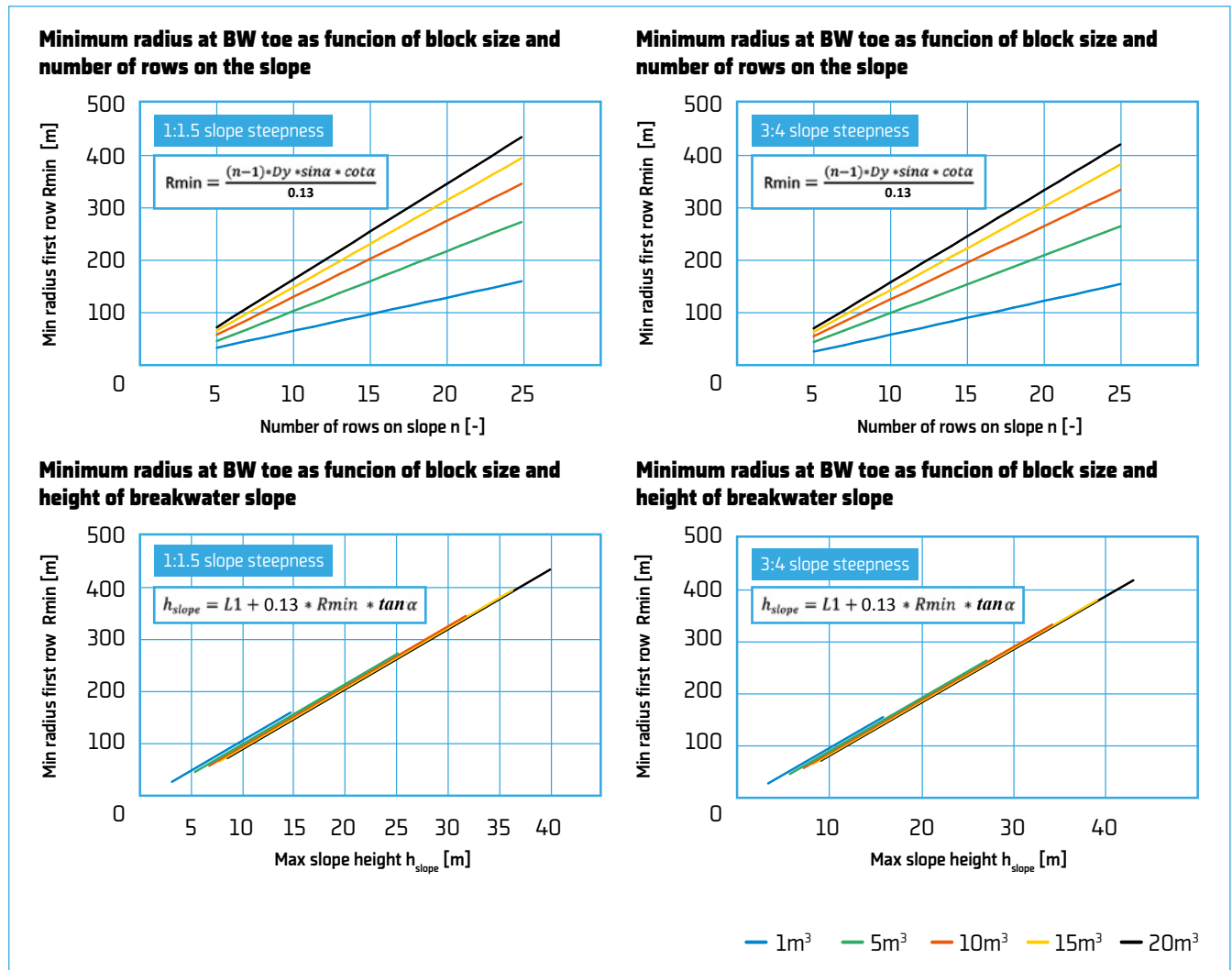
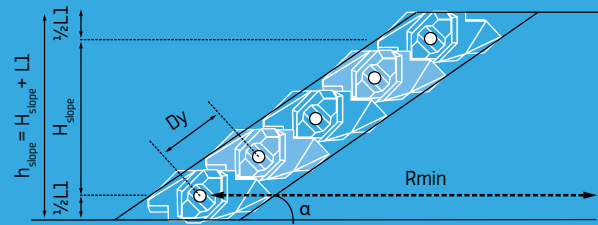

Figure 10-2: Parameters used to determine the minimum radius of a breakwater with XblocPlus



Application of XP-Wing

XblocPlus can be applied on medium curvatures when combined with XP-Wing. XP-Wing is in principle an XblocPlus with a reduced width. By reducing the width of the unit in 2 steps [10% and 20% reduction], the minimum required radius of the breakwater is reduced with 50% compared to normal XblocPlus.

Figure 10-3: Application of XP-Wing with XblocPlus on curved sections

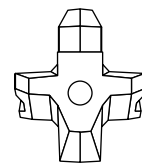
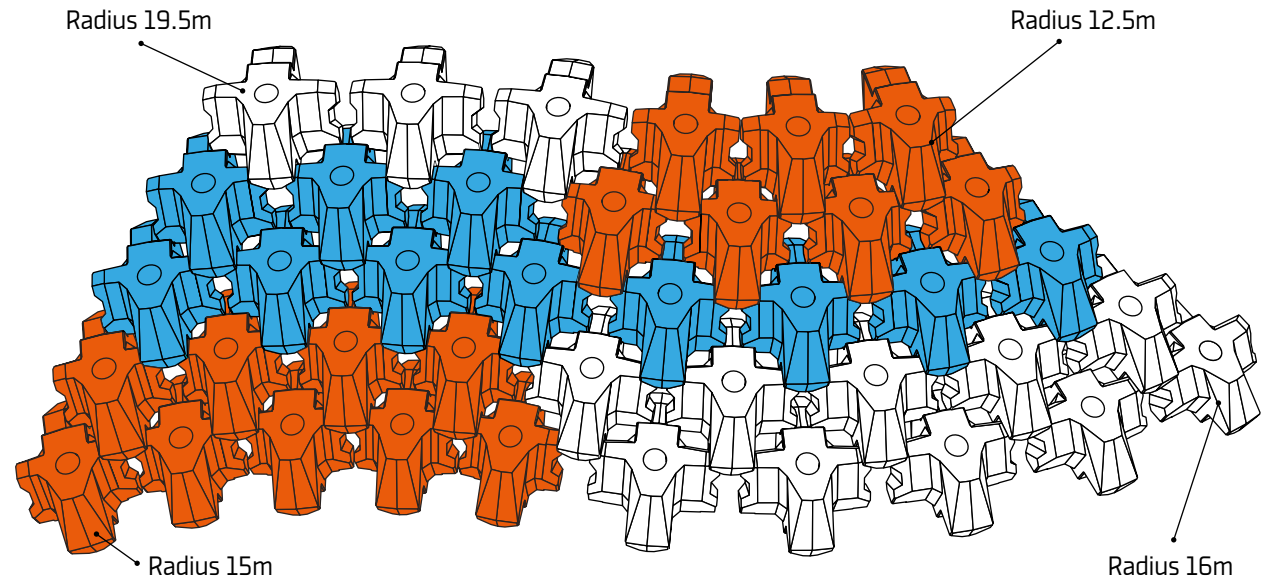

XblocPlus

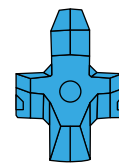

XP-Wing 90% of XblocPlus width



XP-Wing 80% of XblocPlus width

Block Size on Breakwater Head

XblocPlus and XP-Wing are not used on a breakwater head. Therefore no correction factor is required for the block size of these units.

For strongly curved sections and breakwater heads, Xbloc is applied. For these cases, the Xbloc size is designed with a factor of 1.25 compared to the block size on the trunk. This means that the weight of the Xbloc armour units at the head section is 25% heavier than Xbloc units at the trunk section.

Minimum Radius of Xbloc Breakwater Head

The minimum radius of a breakwater head section with Xbloc armour [R] is 2.5 times the design H_s taken at design high water level [DHWL]. If a larger armour unit is applied than based on a correction factor of 1.25, the minimum radius is 6 times the characteristic height [D] of the Xbloc size. A typical design of a breakwater head is shown in Figure 10-4.



Figure 10-4: Typical design of a breakwater head section

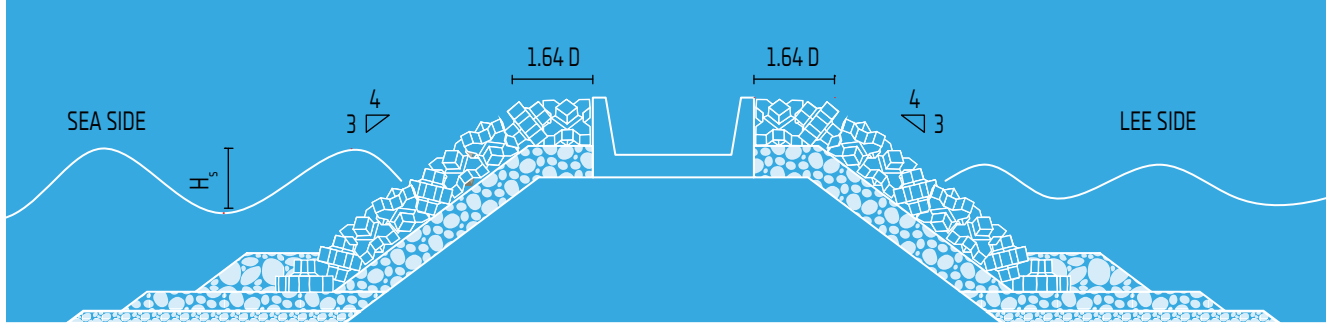

Figure 10-5: Xbloc armour layer supporting marine life



11.0 / TRANSITIONS

The following transitions can be found on an Xbloc or XblocPlus structure:

- Transitions between rock armour and Xbloc
- Transitions between 2 Xbloc sizes
- Transitions between rock armour and XblocPlus
- Transitions between 2 XblocPlus sizes
- Transitions between XblocPlus and Xbloc.



Figure 11-1: Transition between Xbloc and rock armour



Figure 11-3: Transition between 2 sizes of Xbloc

11.1 TRANSITIONS ROCK ARMOUR TO XBLOC

The transition between rock armour and Xbloc armour is made by ending the Xbloc layer in a triangle and placing the rock armour against it [Figure 11-1].

The rock layer is typically thicker than the Xbloc layer. In order to prevent rocks to roll down the Xbloc slope, the rock layer shall not stick out by more than $0.5 \times D_{n50}$ [Figure 11-2].

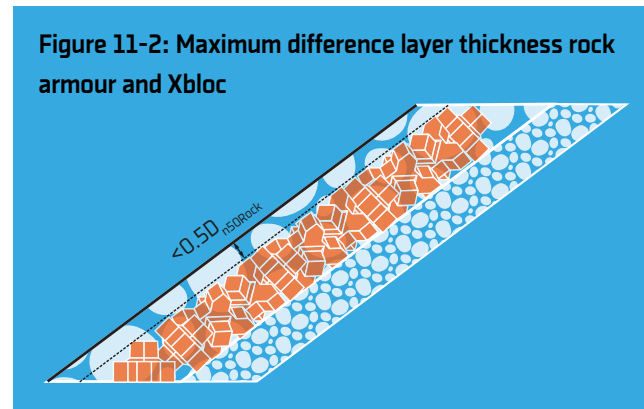

Figure 11-2: Maximum difference layer thickness rock armour and Xbloc

11.2 TRANSITIONS BETWEEN XBLOC SIZES

Transitions between Xbloc sizes are realized with standard Xbloc units where the small blocks are placed over the large blocks [Figure 11-3].

The transition shall be located in the area where the smallest unit size is stable.

The maximum recommended step is tripling of the unit size [e.g. from 2m^3 to 6m^3 units]. The large blocks shall not stick out by more than 33% of their layer thickness h [Figure 11-4].

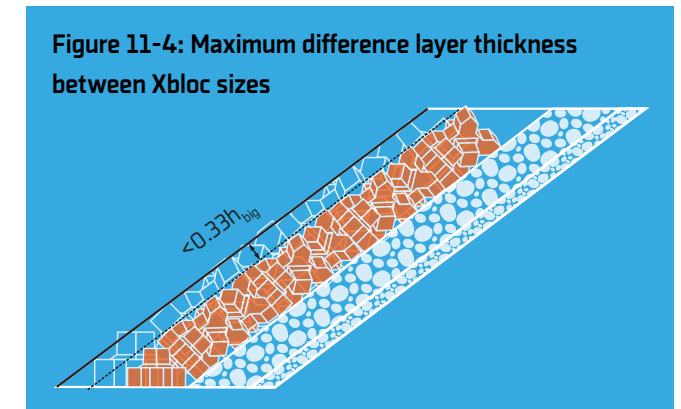

Figure 11-4: Maximum difference layer thickness between Xbloc sizes

11.3 TRANSITIONS ROCK ARMOUR TO XBLOCPLUS

The transition between rock armour and XblocPlus armour is made by ending the XblocPlus layer in a triangle and placing the rock armour against it [Figure 11-5].

The rock layer is typically thicker than the XblocPlus layer. In order to prevent rocks to roll down the XblocPlus slope, the rock layer shall not stick out by more than $0.5 \times D_{n50}$ [Figure 11-6]



Figure 11-5: Transition between XblocPlus and rock armour

11.4 TRANSITIONS BETWEEN XBLOCPLUS SIZES

Transitions between different sizes of XblocPlus units are realized with XP-Trans where the smaller blocks are placed over the bigger blocks. This transition is shown in Figure 11-7. Transitions have been tested for blocks sizes up to a ratio of 1:3 [e.g. from blocks of 2m^3 to blocks of 6m^3]. Larger steps may be possible but are subject to physical model tests. The large blocks shall not stick out by more than 33% of their layer thickness h [Figure 11-8].



Figure 11-7: Transition with XP-Trans units between different unit sizes of XblocPlus

11.5 TRANSITIONS WITH XBLOC AND XBLOCPLUS UNITS

It is possible to use a combination of Xbloc and XblocPlus units for different reasons. Breakwater roundheads for example are usually not protected with XblocPlus units but with Xbloc units. The transition between the XblocPlus units and Xbloc units is realized in a diagonal line the same way as in the transition between different unit sizes [see Figure 11-9]. The XblocPlus armour is ended by reducing the number of units in a row by one for each row up the slope. The Xbloc units are then placed against this diagonal line. The Xbloc shall not stick out by more than 33% of their layer thickness h [Figure 11-10].



Figure 11-9: Transition between XblocPlus and Xbloc

Figure 11-6: Maximum difference layer thickness rock armour and XblocPlus

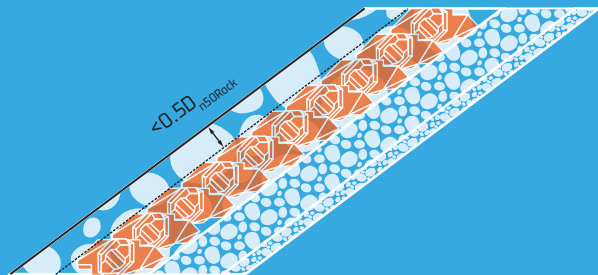

Figure 11-8: Maximum difference layer thickness between XblocPlus sizes

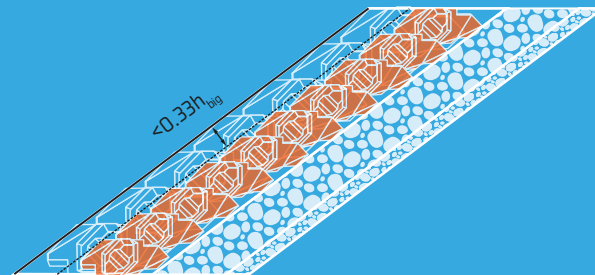
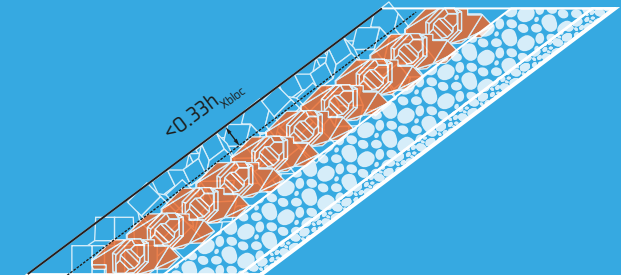

Figure 11-10: Maximum difference layer thickness between Xbloc and XblocPlus



12.0 / CONDITIONS OF USE

34

DMC is a trademark of BAM Infraconsult B.V., a private company with limited liability, with registered office at H.J. Nederhorststraat 1, Gouda, The Netherlands.

DMC is holder of several patents, patent applications and trademarks in relation to the Xbloc unit, Xbase unit and XblocPlus unit. The Xbloc unit, the Xbase unit and the XblocPlus unit are known and legally protected by the trademarks Xbloc and Xbase.

For the use of Xbloc and XblocPlus, a signed Xbloc License Agreement is required between Client and DMC.

In this document DMC provides some considerations for designers who intend to incorporate Xbloc armour units in a design [further referred as Designer].

The following conditions apply to the guidelines presented by DMC in this document.

- This document is based on DMC's current professional insights. Changes in these insights may lead to changes in the contents of this document. Before using this document, Designer is requested to check if this document is the latest revision.
- This document does not contain a complete description of all factors that affect a design.
- Designer shall be responsible for designs made by using the contents of this document and shall take into account the various factors that affect the design.
- DMC shall not be liable for any direct and/or indirect or consequential damages or losses such as loss of revenue, loss of profit, loss of anticipated profit, loss of use, production, product, productivity, facility downtime and business opportunity resulting from the use by Designer of the contents of this document.
- The guidelines provided by DMC regarding the design with Xbloc and XblocPlus armour units are subject to confirmative physical model tests.
- All information provided by DMC concerning [the application of] Xbloc and XblocPlus armour units is proprietary information of DMC. It shall not be disclosed by designer to any third parties.
- The relationship between Designer and DMC shall be governed by the law of The Netherlands and any disputes arising out of or in connection with the work carried out by DMC shall finally be settled by the competent courts in The Hague.

xbloc® is a product of:

dmc
marine consultants

A BAM company



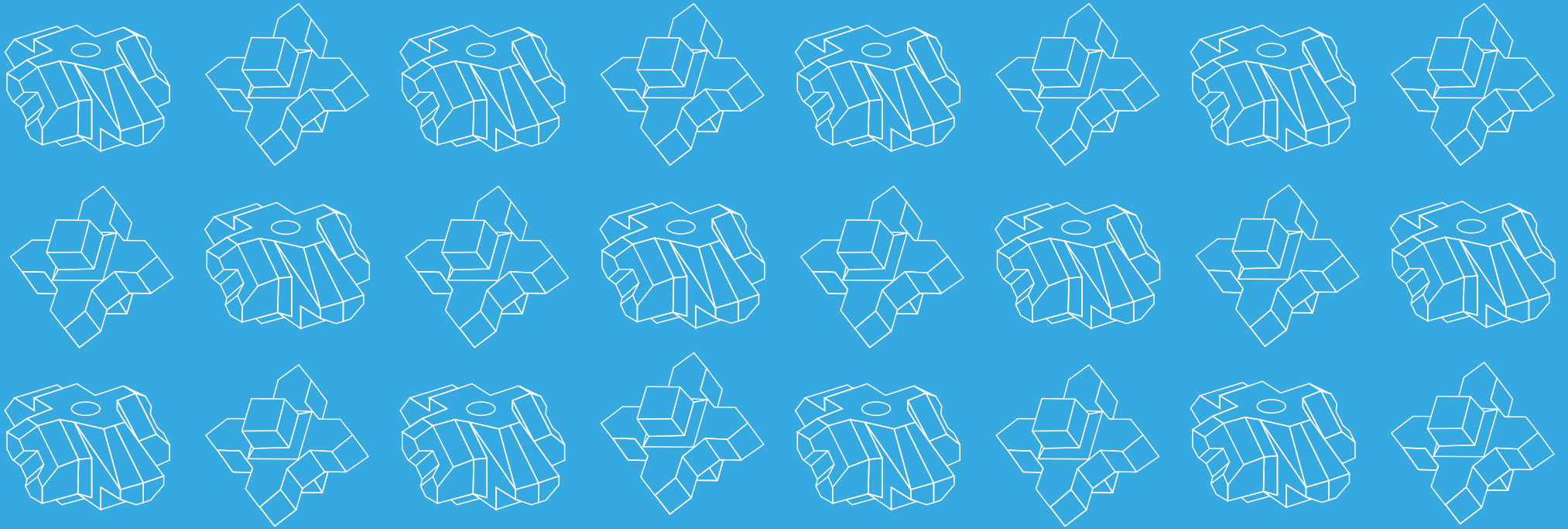

RESILIENT
ECONOMICAL
SUSTAINABLE

